

Chapter 6 LD(Ladder Diagram)

6.1. Overview	6-1
6.2. Power rails.....	6-1
6.3. Connection line	6-2
6.4. Contacts	6-3
6.5. Coils	6-4
6.6. Calling functions and function blocks	6-5

6. LD(Ladder Diagram)

6.1. Overview

- LD program expresses PLC program through graphic symbol such as coil or contact normally used in the relay logic diagram.
- Type

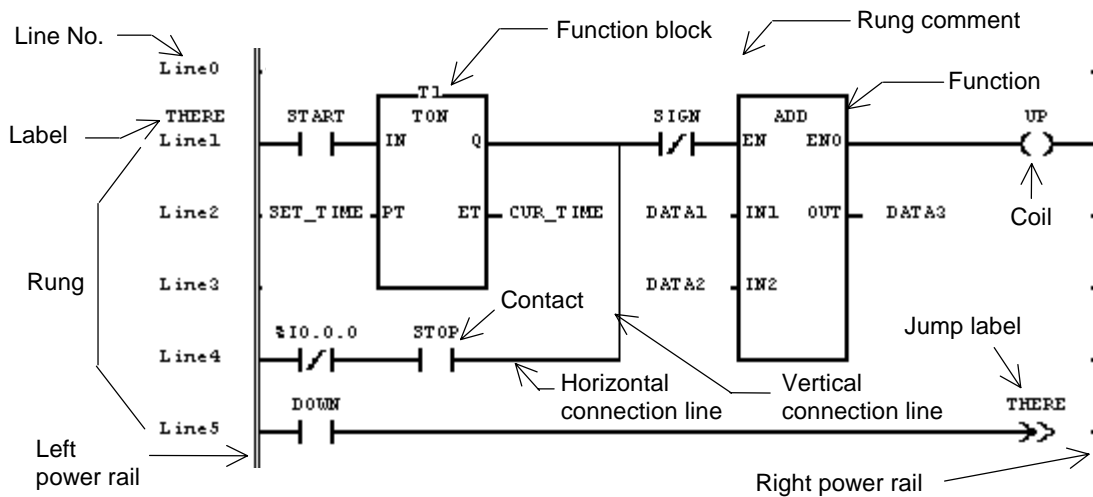

6.2. Power rails

- Base line of power line concept is laid in the left and right end of LD graphic diagram.

No.	Symbol	Description
1		Left power rail (with attached horizontal connection line) Has BOOL 1 value always.
2		Right power rail (with attached horizontal connection line) Value is not defined.





6.3. Connection line

- BOOL 1 value of left power rail is transferred to the right according to the connection. The line having transferred value is called as power flow line or connection line that is connected to the contact or coil. Power flow line always has BOOL value and only one exists in one rung. The rung means the line without the down-directed line from LD start.
- The connection line consists of horizontal and vertical connection line to connect each LD element.

No.	Symbol	Description
1		Horizontal connection line Transfer left value to right.
2		Vertical connection line Logical sum of horizontal connection lines at left side

6.4. Contacts

- The contact transfers the horizontal connection line status, BOOL input/output, or Boolean AND of memory variables to the horizontal connection line at right side. The contact does not change the variable value relating to contact. The standard contact symbols are as below.

Static contacts		
No.	Symbol	Description
1	<p style="text-align: center;">***</p> 	<p style="text-align: center;">Normally Open Contact</p> <p>When BOOL variable (marked by "****") is ON, left connection line is copied to the right. Otherwise, right connection is OFF.</p>
2	<p style="text-align: center;">***</p> 	<p style="text-align: center;">Normally Closed Contact</p> <p>When BOOL variable (marked by "****") is OFF, left connection line is copied to the right. Otherwise, right connection is OFF.</p>
Transition sensing contacts		
3	<p style="text-align: center;">***</p> 	<p style="text-align: center;">Positive transition-sensing contact</p> <p>The state of the right connection is ON from one evaluation of this element to the next when a transition of the associated variable from OFF to ON is sensed at the same time that the state of the left connection is ON. The state of the right connection shall be OFF at all other times.</p>
4	<p style="text-align: center;">***</p> 	<p style="text-align: center;">Negative transition-sensing contact</p> <p>The state of the right connection is ON from one evaluation of this element to the next when a transition of the associated variable from ON to OFF is sensed at the same time that the state of the left connection is ON. The state of the right connection shall be OFF at all other times.</p>

6.5. Coils

- Coil stores the result of left connection status or status transition to related BOOL variable. The standard coil symbol is as below.

Momentary Coils		
No.	Symbol	Description
1	$\begin{array}{c} *** \\ \text{--- () ---} \end{array}$	<p style="text-align: center;">Coil</p> <p>The state of the left connection is copied to the associated BOOL variable (marked by "****")</p>
2	$\begin{array}{c} *** \\ \text{--- (/) ---} \end{array}$	<p style="text-align: center;">Negated Coil</p> <p>Input negated left connection line status to the associated BOOL variable (marked by "****"). If left connection line is OFF, it switches relating variable ON and if left connection line ON, it switches relating variable OFF.</p>
Latched Coils		
3	$\begin{array}{c} *** \\ \text{--- (S) ---} \end{array}$	<p style="text-align: center;">Set (Latch) Coil</p> <p>When left connection is ON, associated BOOL variable (marked by "****") is ON till reset by a reset coil.</p>
4	$\begin{array}{c} *** \\ \text{--- (R) ---} \end{array}$	<p style="text-align: center;">Reset(Unlatch) Coil</p> <p>When left connection is ON, associated BOOL variable (marked by "****") is OFF till set by a set coil.</p>
Transition-Sensing Coils		
5	$\begin{array}{c} *** \\ \text{--- (P) ---} \end{array}$	<p style="text-align: center;">Positive Transition-Sensing Coil</p> <p>When the left connection (marked by "****"), which is OFF during previous scanning, is ON during current scanning, value of the associated BOOL variable (marked by "****") is ON only during current scanning.</p>
6	$\begin{array}{c} *** \\ \text{--- (N) ---} \end{array}$	<p style="text-align: center;">Negative Transition-Sensing Coil</p> <p>When the left connection (marked by "****"), which is ON during previous scanning, is OFF during current scanning, value of the associated BOOL variable (marked by "****") is ON only during current scanning.</p>

- Coil can be located only at right side of LD. There's only right power rail at the right of coil.

6.6. Calling functions and function blocks

- Actual Input/Output connection for the function or function block is arranged by describing proper data or variable to the outside of function or function block body.

Example

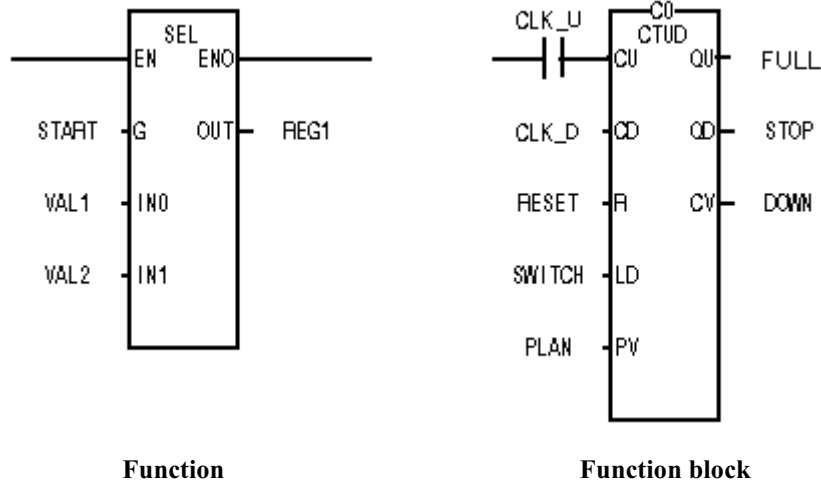

- A BOOL type input and output shall be located at each function or function block in order to allow the power flow into the function or function block. EN and ENO is BOOL type Input/Output at the function and first input and output is BOOL type at the function block.

Example

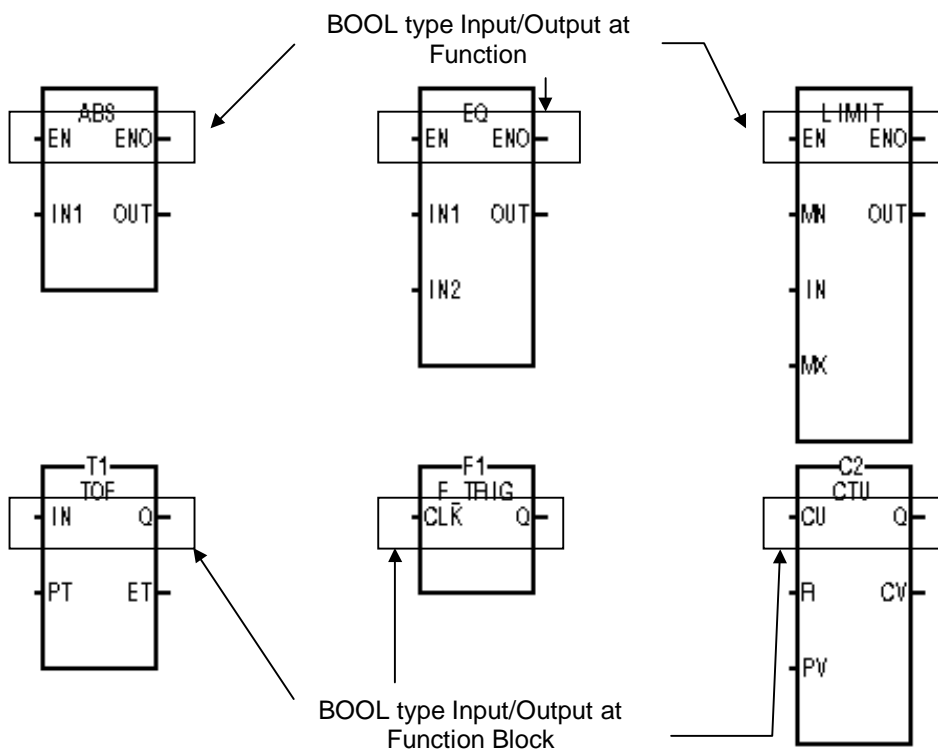

- The function at LD has EN input and ENO output unlike IL. EN and ENO are BOOL data type and the function is executed when EN input is BOOL 1 and is not executed when it is BOOL 0. ENO output is generally EN value but ENO will be BOOL 0 though EN is BOOL 1 when the function error occurs. The function's EN shall be power flow line but ENO may not be. However, when the power flow line is connected to the function output not ENO, the output data type shall be BOOL. Further, if the power flow line is connected to the function output not ENO, ENO shall not be connected to anything. All inputs of function are allocated by describing the value to left of the function and shall not be missed. The function's output is stored to the variable selected to right of the function.
- The function block at LD is used as same method at IL. The function blocks input is selected as same method. As the function blocks output is stored in the instance, the variable may not be selected. As EN and ENO Input/Output are not in the function block, the function is executed at every function block. Therefore, the jump(-->>) shall be used to define the execution of function block according to logical result. When the power flow line is connected to the function block, it shall be connected to Input/Output of BOOL data type.

Example

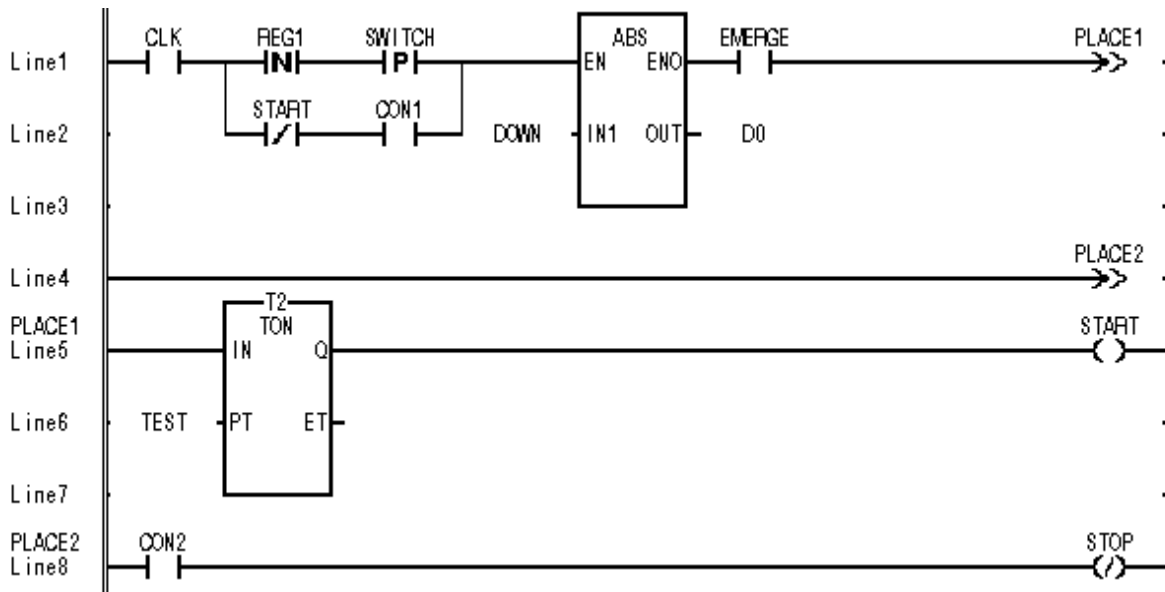

- The function and function block can be located everywhere at LD. Connecting power flow line to function and function blocks Input/Output and contact to power flow line can continue the logic operation.

Example

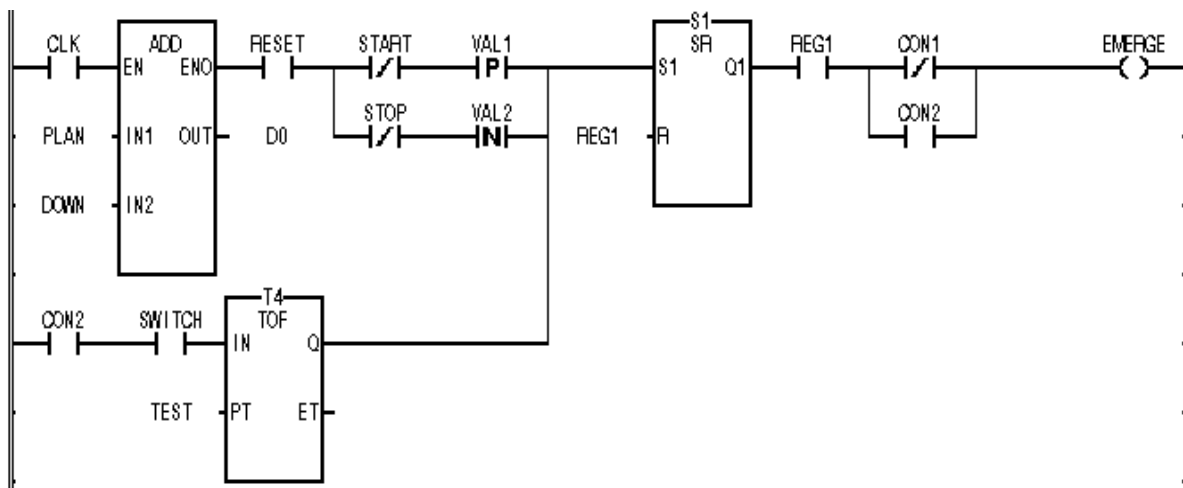

- The power flow line, which can be connected to one function and one function block, is only one.

Example

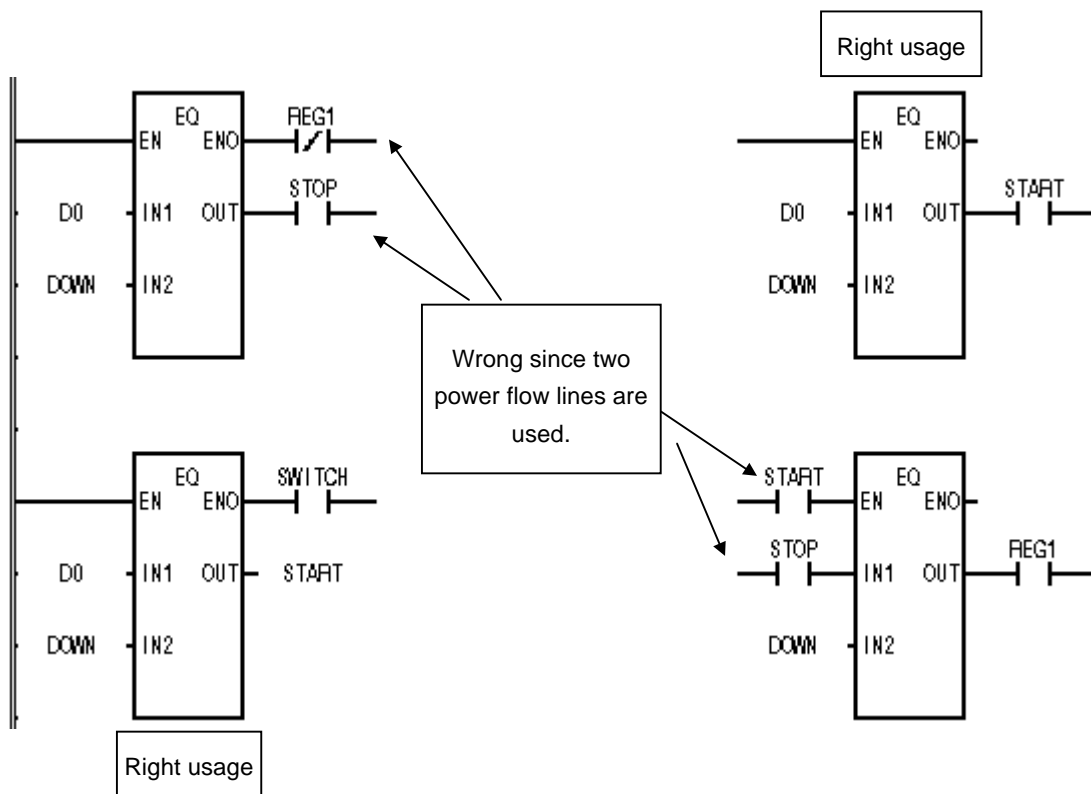

MEMO

